

fitt bluforce rj

A technology worth spreading

Polymer alloy pipes with restraint system

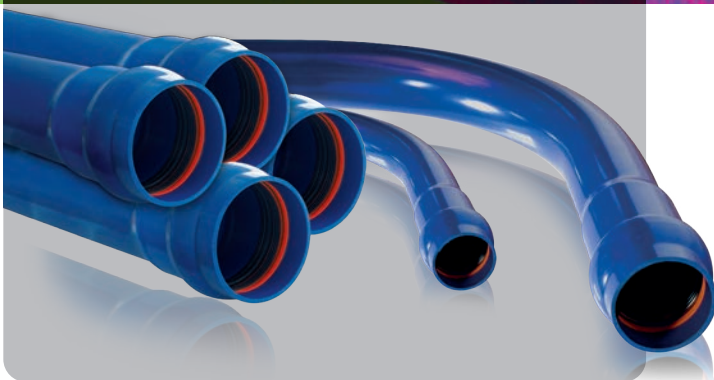

fitt® building | 

fit^s bluforce rj

Polymer alloy pipes with restraint system

Fitt, a leading global group founded in Italy in 1969 – today a certified B Corp – is a pioneer in the production and development of highly innovative solutions aimed at the passage of fluids for domestic, professional and industrial use.



Ingenious for life

The mission of the FITT Group is to improve the performance of its customers by providing pipes and systems for the transport of liquid, gaseous and solid substances, with cutting-edge products in terms of technology, design and sustainability.

A story in the making

FITT, led today by Alessandro Mezzalira, was founded in 1969 by his father Rinaldo. Headquartered in Sandrigo, in the province of Vicenza, FITT - as an international reference point in its industry - now has 15 production sites (9 in Italy, 5 in Europe and 1 in the USA), 16 logistics sites worldwide and 6 commercial branches.

FITT SOLUTIONS



Gardening Solutions



Industrial Solutions



Marine Solutions



Food & Beverage Solutions

Innovation and pioneering technology

Innovation and pioneering technology
FITT strongly believes in the principle of Open Innovation and collaborates with an international network of partners, universities and research centres. It relies on external organizations to validate protocols and quality tests and to map the environmental impact of its products.

Multiplant production and logistics

Automated, agile, customized logistics able to adapt to the demands of the different sales channels of large customers with a service that provides both the central and the single point of sale, up to the private individual who buys online. FITT's network of logistics centers, strategically located throughout Europe, allows delivery in 48/72 hours in the main European markets.

FITT Divisions

The FITT Group is organized into three divisions - **FITT Industrial; FITT Garden; FITT Building** - each autonomous in their respective markets and with specialized skills to offer cutting-edge and sustainable solutions.

FITT Vision 2033

FITT recognizes that the flow of life comes from the health of the planet and its people. This is why it is committed to preserving and protecting water, an essential and irreplaceable resource. For FITT, taking care of the planet and its people means having a positive impact on: Environment Lite, Business Lite, People Lite.



Building
Solutions



Pool & SPA
Solutions



Ventilation
Solution



Agriculture
Solutions



Infrastructure
Solutions

«the task that we are called to fulfil must contribute to make this world a better place, for us and for future generations»

Alessandro Mezzalira
CEO

Certified



This company meets high standards of social and environmental impact.

Corporation

The path of FITT

FITT believes in a business model capable of generating shared value for people, society and the environment. Since 2019, it has embarked on a structured path towards sustainability, becoming a Benefit Corporation, defining the strategy The Responsible Flow 2030 and obtaining B Corp certification in 2024.

Benefit Corporation: value beyond profit

Since 2021, FITT has officially been a Benefit Corporation. This means that, alongside economic objectives, the company pursues goals of common benefit, integrating the positive impact on people, territories and the environment into its mission.

The value of B Corp certification

In 2024, FITT obtained B Corp certification, joining a global community of companies that use business as a force for good. This milestone establishes the company's commitment to integrated and transversal sustainability, measured through a rigorous standard that assesses the impact on five areas: Governance, Workers, Community, Environment and Customers. Being a B Corp means operating in a transparent, responsible and inclusive way, with the aim of generating shared value and actively contributing to a fairer and more regenerative economic model. Certification is not a point of arrival, but a new beginning towards continuous improvement.

THE 7 OBJECTIVES SELECTED BY FITT





Redesigning processes responsibly

FITT is also taking concrete action on the operational front: it has certified its **organisational carbon footprint (ISO 14064-1)** and started the process towards **ISO 14001 certification** for all its plants. Interventions in logistics, waste management and the reduction of water consumption through closed circuits go hand in hand with an increasing use of **energy from renewable sources**, with the aim of reducing the environmental impact along the entire value chain.

Products: innovating to have less impact

Product innovation is guided by the principles of **ecodesign** and the certified measurement of the **carbon footprint (ISO 14067) certified by TUV**, with solutions designed to be light, high-performance and circularity-oriented.

This approach makes it possible to promote **transparency and awareness** towards customers and the market, with a view to continuously improving environmental performance.

Well-being, equity, participation

FITT puts **people at the centre**: it promotes listening, participation and enhancement through focus groups and continuous training, and has obtained **certification for gender equality (UNI/PdR 125:2022)**. By adhering to the **Women's Empowerment Principles**, it invests in organizational well-being, welfare and flexibility, for an increasingly inclusive, equitable and sustainable work environment.



fitt bluforce rj why the restraint system?

The evolution of the innovative polymer alloy pipe PVC-A (PVC-HI)*, now available with an integrated restraint system

The experience acquired in recent years with the production and promotion of the polymer alloy technology has confirmed the need to supply market players with a premium-quality product that is also capable of satisfying the highest technical-application standards in both the integrated water resources management market and the irrigation sector.

The overall expenditure for important projects such as water supply pipelines, sewage lifting stations and water infrastructures depends on the initial costs, but above all on the management and maintenance costs throughout the entire service life of the infrastructure, which should be as durable as possible and trouble-free.

To satisfy these needs, FITT – after developing the innovative FITT Bluforce technology and incorporating the inputs coming from the market (designers and managing bodies) – presents **FITT Bluforce RJ: for the first time in Europe**, a pipe made of thermoplastic material with an integrated and immovable mechanical sealing system.

FITT Bluforce RJ conforms to the IIP 1.1/19 technical specification, “Modified polyvinyl chloride (PVC-A) pipes for water conveying pipelines”, (Italian) Ministerial Decree no. 174 of 6 April 2004 (Water for human consumption) and the UNI EN 1622 standard, “Water analysis – determination of the threshold odour number (TON) and the threshold flavour number (TFN)”.

FITT Bluforce RJ, as a restrained PVC-A (PVC-HI) pipe, **is referenced in UNI 11990-3:2026**, the standard for guided drilling systems: Horizontal Directional Drilling (HDD).

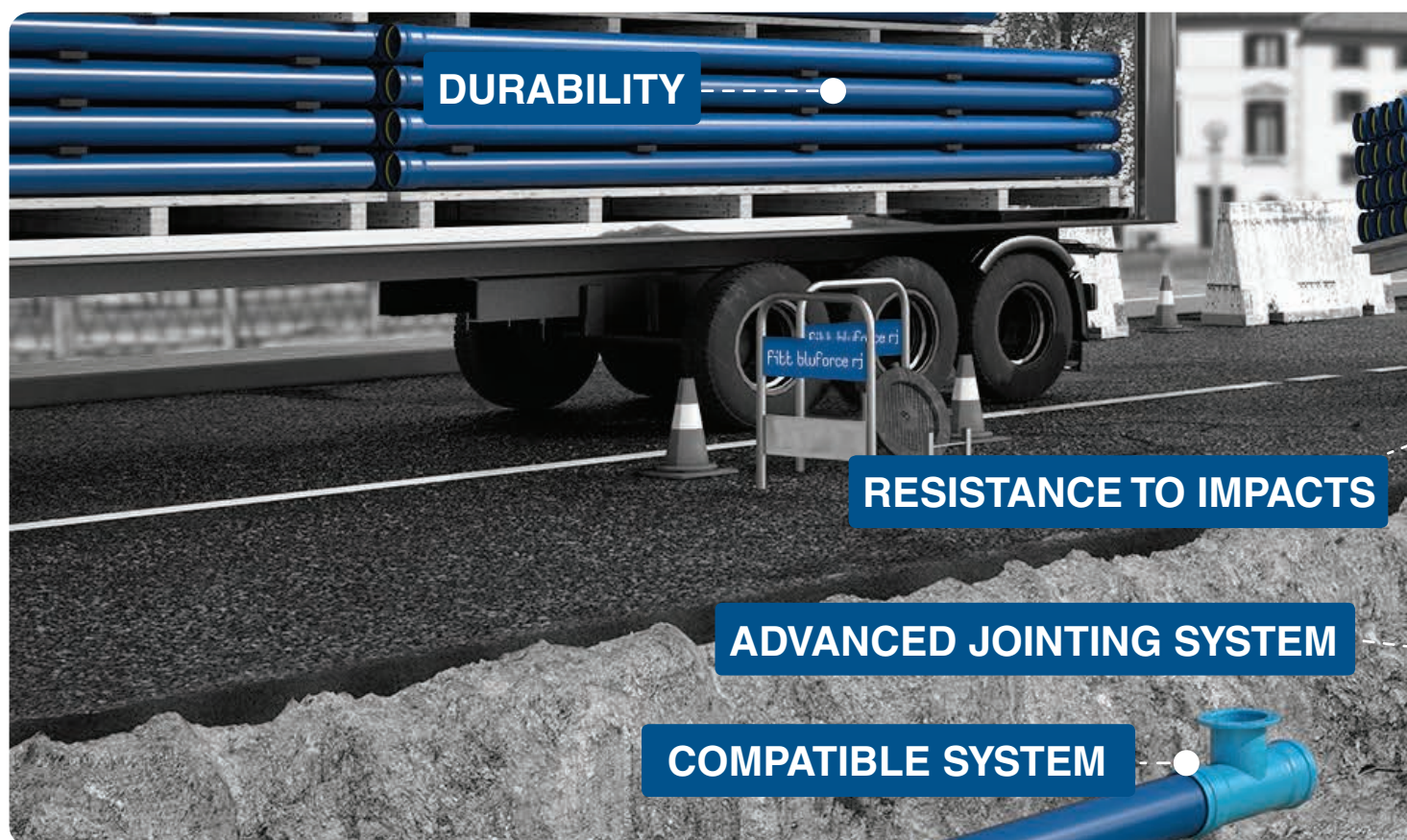



A	B	C
A K75 KIP-104537	B FITT Bluforce is Made in Italy.	C Technical Specification IIP (MOD 1.1/19)

In 2020 FITT Bluforce RJ obtains the certification **Kiwa Quality** thanks to which, based on type tests as well as the periodic inspections conducted by Kiwa, is deemed compliant with the requirements of the Technical Document Ki-0410 Rev. 12, Annex K75 Rev. 03 and therefore marked KQ. Kiwa certification was issued in agreement to the Kiwa Cement Italia Regulations for Certification of product.

FITT has always cooperated with operators in the water cycle market in an effort to develop products capable of solving various necessities: in actual fact, this innovation was developed by incorporating the requests of designers and technicians of the managing bodies.

The design and construction needs of the modern ones networks have to adapt to the ever increasing difficulties represented by the proliferation of sub-services that do not allow more the creation of containment works thrust, such as anchor blocks.

The changed hydrogeological and climate conditions require pipes capable of withstanding sudden stress such as shifts in the laying terrain, or unforeseeable movements such as landslides caused by heavy rainfall.

() At a regulatory level, it is defined as a polymeric alloy of Poly Vinyl Chloride with high impact strength PVC-HI (such as PVC-M, PVC-A, PVC-CPE). PVC-HI (PVC-M, PVC-A, PVC-CPE) is a thermoplastic material that contains PVC resin with the addition of an impact modifier (PVC-High Impact). Depending on the type of impact modifier, the acronym HI can be replaced with various designations (PVC-A, Acrylic or PVC-A Alloy (polymer alloy); PVC-CPE, Chlorinated Polyethylene; PVC-M, Modified).*

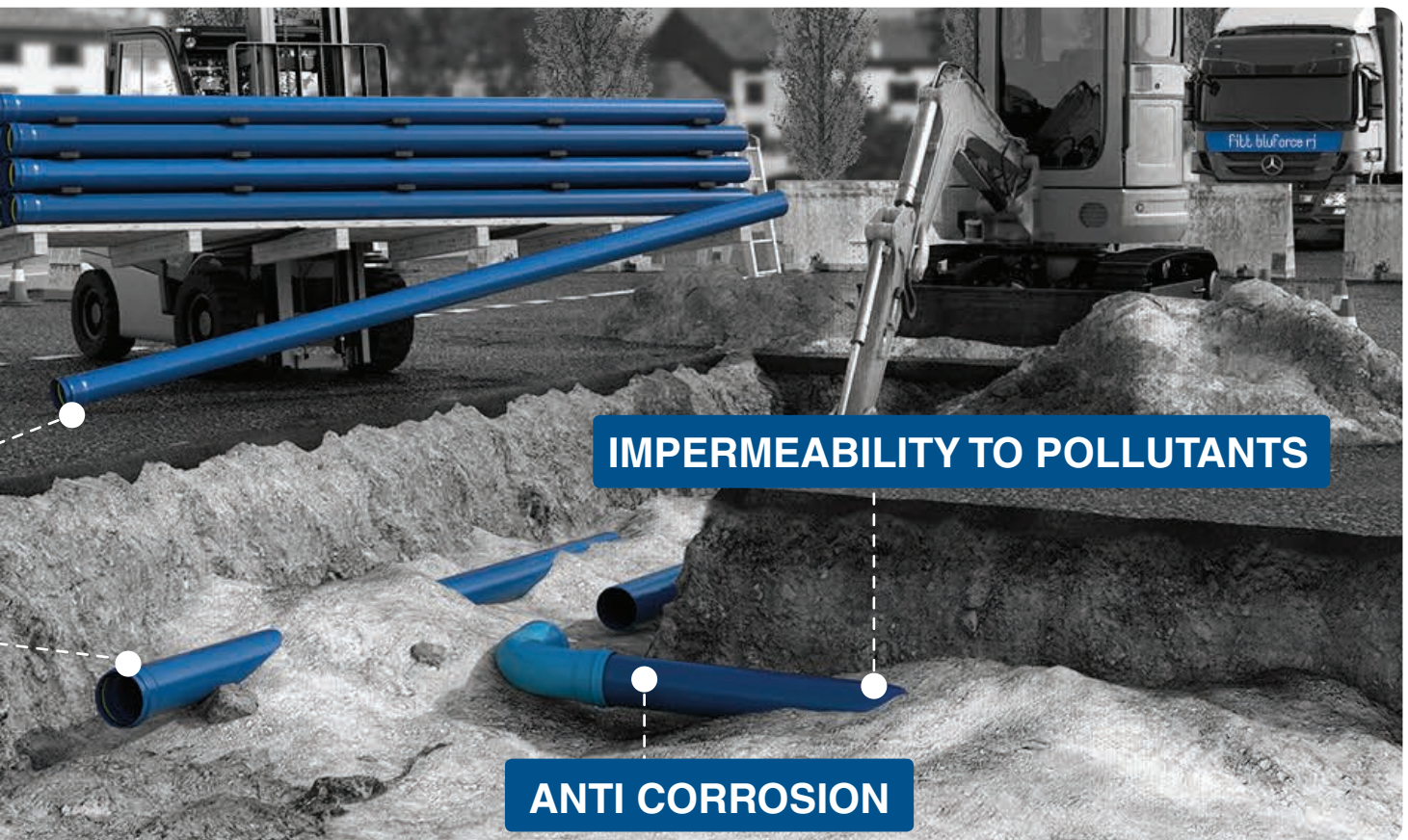

the solution? fitt bluforce rj

FITT Bluforce RJ, – where “RJ” refers to “restraint joint” – can solve a series of necessities concerning both the design and laying phases, besides ensuring durable operation.

For designers it is far easier to design pipelines with restraint systems that do not require complex calculations to create thrust blocks; moreover, with the same type of pipe they can create sections that require mechanical seals and sections that do not require this technology.

Likewise, the company will have an easier task in laying the pipes, as they do not require external joints or, alternatively, concrete thrust blocks to be fitted in the restraint sections. Moreover, like for other polymers, long and delicate material welding operations are no longer necessary.

For the managing body it is an optimal solution for safely and rapidly completing network extensions and maintenance works on existing pipelines, resulting in shorter work times on-site without adversely affecting the durability of the polymer alloy technology.

This new alloy, termed **PVC-A (PVC-HI)***, was used by FITT to manufacture **FITT Bluforce RJ**, which is currently able to guarantee:

- extreme ductility and thus the absence of brittle fracture
- considerable resistance to impacts and point loads even at low temperatures
- high resistance to crack propagation
- excellent tolerance to chemical aggression
- invulnerability to stray currents
- lower weight – with diameter being equal – compared to conventional resin and metal pipes
- advantageous hydraulic section compared to pipes made of other thermoplastic materials.

FITT Bluforce RJ is made with virgin polymers and exclusively incorporates organic-based stabilisers (OBS), which makes it lead-free.

With **FITT Bluforce RJ** it is possible to create large-radius bends by exploiting the flexibility of polymer alloy.

MAXIMUM PERMISSIBLE CURVATURE

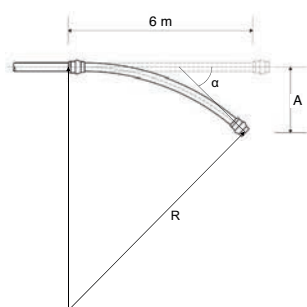

FITT BLUFORCE RJ

DN [mm]	A [m]	L [m]	α [°]	R [m]
90	1,30	6	18,6	9,2
110	1,10	6	15,8	10,9
160	0,75	6	10,7	16,0
200	0,60	6	8,6	20,0
225	0,50	6	7,2	24,0
250	0,45	6	6,4	26,7
315	0,37	6	5,3	32,4
400	0,28	6	4	42,9



The **FITT Bluforce RJ** technology adds tensile strength to the properties that already characterise FITT Bluforce: the external diameter being equal,

FITT Bluforce RJ has an improved hydraulic section compared to other thermoplastic products normally used to convey drinkable water under pressure;

ENHANCED FLOW RATE (liter/second)

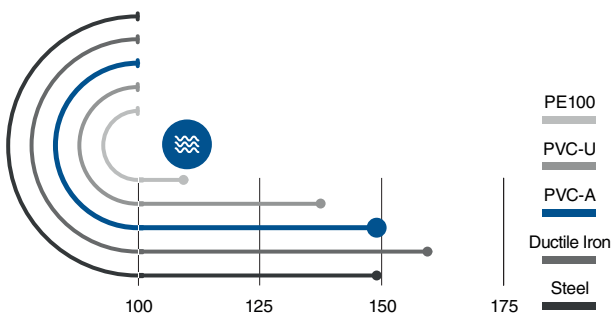

The external diameter being equal, **FITT Bluforce RJ** has an improved hydraulic section compared to other thermoplastic products normally used to convey drinkable water under pressure;

HIGH LAYING SPEED (meter/hour)

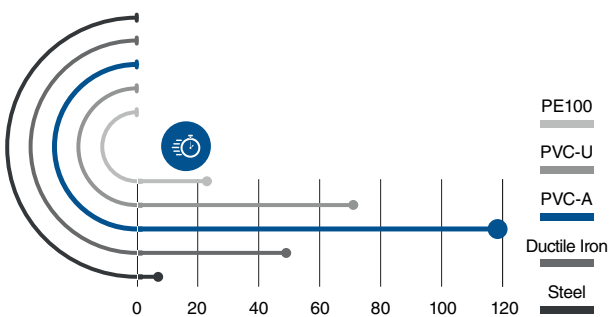

The technology based on the immovable seal hot-inserted in advance makes pipe laying easy and safe also in complex trenches, thus reducing the work times on-site;

LOWER WEIGHT (Kg/m)

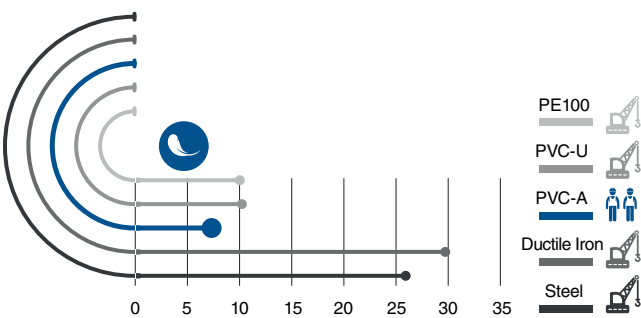

Up to 200 PN 16 diameter included, the pipe can be handled manually by two operators without falling out of the parameters of (Italian) Leg. Decree no. 81/2008.

All data is calculated for DN200 pipes (PE100, PVC-U and PVC-A: PN16).
 The flow rate is calculated using a straight section measuring 1,000 metres with 12 bar internal pressure.
 The laying speed is calculated without considering the trench excavation and backfilling phases.
 The handling indications refer to 6-metre pipes and comply with the parameters of (Italian) Legislative Decree no. 81/2008

the FITT bluforce epd® - environmental product declaration



FITT Bluforce is the first PVC-A (PVC-HI)* product range to achieve EPD® marking in Europe. This is the environmental product declaration that provides certified data on the life cycle of products, following the ISO 14025 and EN 15804:2012 + A2:2019/AC:2021 international standards.

The FITT Bluforce range provides utilities and freelance professionals with a wide range of solutions for infrastructural networks, now also completed with certified information on product environmental footprint.

FITT Bluforce and FITT Bluforce RJ meet the requirements for green procurement of Public Administrations (Green Public Procurement) and the Minimum Environmental Criteria for the road and building construction and maintenance sectors.

EPD®, WHAT IS IT?

The EPD® is a voluntary certification program that started in Sweden, and soon took on an international position as part of the EU environmental policy.

The EPD® follows the requirements of the **UNI EN ISO 14025:2010** standard (Environmental declarations and labels – Type III environmental declarations) and is a tool for providing objective, comparable and reliable information on the environmental performance of products and services.

On one side, this declaration allows manufacturers to demonstrate their commitment to environmental issues, by analysing and describing their products in terms of their environmental impacts, while on the other side giving customers, designers and contractors the possibility of obtaining detailed information regarding the environmental characteristics of the product itself.

This means that the EPD® of the Bluforce range can provide relevant, checked and comparable information on the environmental impact of the **PVC-A (PVC-HI)*** drinking water distribution network system conceived by FITT.



(*) At a regulatory level, it is defined as a polymeric alloy of Poly Vinyl Chloride with high impact strength PVC-HI (such as PVC-M, PVC-A, PVC-CPE). PVC-HI (PVC-M, PVC-A, PVC-CPE) is a thermoplastic material that contains PVC resin with the addition of an impact modifier (PVC-High Impact). Depending on the type of impact modifier, the acronym HI can be replaced with various designations (PVC-A, Acrylic or PVC-A Alloy (polymer alloy); PVC-CPE, Chlorinated Polyethylene; PVC-M, Modified).

TÜV
Italia S.r.l.



A

B

A
Third verifier
in accordance with:
ISO 14025:2006.

B
ISO 14025 - EN 15804:2012 + A2:2019/AC:2021
Reg. nr. EPD-IES-0001946:003 (S-P-01946)
environdec.com

THE ADVANTAGES OF THE EPD® CERTIFICATION



Is international

The Bluforce and Bluforce RJ EPD® is a certified Environmental Product Declaration (EPD®) that lists environmental data on the life cycle of Bluforce products, in accordance with international standard ISO 14025.



Is reliable

The Bluforce and Bluforce RJ EPD® is based on the scientific principles of the Life Cycle Assessment (LCA), and is awarded following an independent assessment.



Is transparent

The Bluforce range environmental product declaration data are calculated and presented following the standard calculation rules contemplated for the product category of construction materials.

HOW IS THE ENVIRONMENTAL PERFORMANCE OF THE FITT BLUFORCE RANGE CALCULATED?

The environmental performance of the Bluforce range indicated in the EPD® is based on the **Life Cycle Assessment (LCA)**, in accordance with the **ISO 14040 standard**, the methodological foundation that ensures the objectivity of the information supplied, taking into account the specific calculation parameters for the product category (PCR) of construction materials following the **EN 15804:2012 + A2:2019/AC:2021** European Standard.

The new study adopts the “cradle to grave” approach and quantifies the impacts from the extraction of raw materials to the end of life of the finished product and its disposal. In the EPD®, the results are split into the following stages:

A1: production of raw materials and energy carriers;

A2: transport of raw materials;

A3: manufacturing process at the FITT plant.

A4: transport of the pipe to the installation site;

A5: pipe installation;

C1: removal of the pipe from the installation site;

C2: transport of materials to the disposal and/or recovery center;

C3: waste treatment processes;

C4: waste disposal.

The environmental information obtained through the LCA was transferred in the environmental product declaration, which after having being assessed by **TÜV Italia S.r.l.**, an independent credited body, is now available at environdec.com, the portal of the International **EPD® System**, the Program Operator selected by FITT that manages the processes for the writing of the Product Category rules, with a presence in nearly 50 countries all over the world (to date the environdec.com portal lists nearly 3000 EPD®s).



SCAN the QR Code and discover the Bluforce EPD®!

Visit the environdec.com portal, the **Global International EPD® System** that collects environmental based claims on **ISO 14025** and **EN 15804:2012 + A2:2019/AC:2021**

pressure and tensile test

The entire **FITT Bluforce RJ** restrained pipe range has been subjected to 1,000-hour regression tests according to EN 1452 with internal pressures suitable for Mpa of project extensively passing the tests without no leakage or breakage.

INTERNAL PRESSURE [bar] TEST AT 1,000 HOURS

	PN 16	PN 20
DN [mm]	P int [bar]	P int [bar]
90	28,1	34,8
110	28,2	34,8
160	27,6	34,7
200	27,8	34,8
225	27,8	34,6
250	27,8	34,7
315	27,7	34,7
400	27,4	34,6

Thanks to the data obtained from tensile tests, it is possible to determine the axial tightness of the restrained joint used in **FITT Bluforce RJ**, with values ranging from a minimum of approximately 42 kN for DN 90 PN 16 up to over 360 kN for DN 400 PN 20, as referenced in UNI 11990-3:2026, the standard for guided drilling systems: Horizontal Directional Drilling (HDD).

TENSILE TEST

	PN 16	PN 20
DN [mm]	Breaking load [kN]	Breaking load [kN]
90	42	65
110	45	70
160	97	150
200	115	179
225	153	237
250	134	208
315	222	344
400	232	360

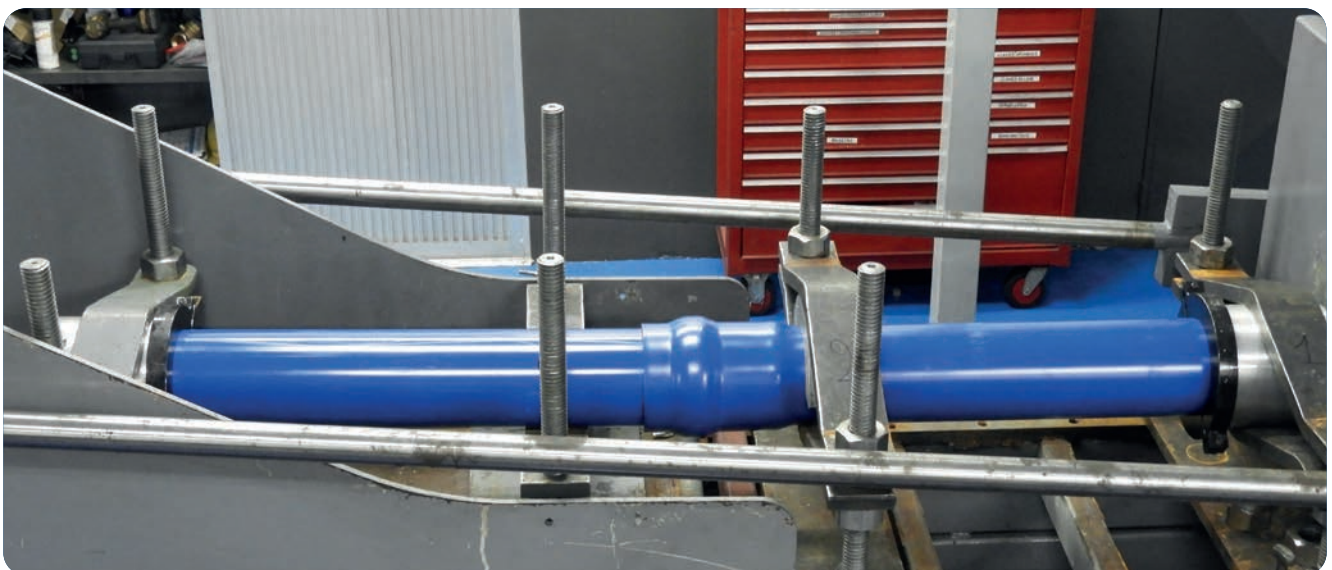

bulldog® sealing system

FITT Bluforce RJ uses the socket-based jointing system with the seal mechanically hot-inserted in advance during the socket forming phase. The Bulldog® seal is made up of three elements that guarantee both the hydraulic and mechanical tightness of the joint:

- EPDM rubber sealing ring conforming to the EN 681 standard, certified according to Ministerial Decree no. 174/2004
- GJS 450-10 ductile iron envelope with epoxy protection applied through cataphoresis
- GJS 450-10 ductile iron mechanical sealing ring with epoxy protection applied through cataphoresis.

This hot pre-insertion method guarantees a totally stable seal, resulting in easy assembly, perfect functionality and optimal hydraulic and mechanical tightness of the pipes over time. The Bulldog® system is characterised by:

- rapid installation, thanks to the low assembly force
- high hydraulic tightness, certified by tests conducted in pressurised and depressurised conditions
- high mechanical tightness, guaranteed by the GJS 450-10 ring.

Thanks to this technology, it is possible to build pipelines without creating thrust blocks. Moreover, the pipes can be laid on terrains that are strongly sloping or prone to landslides.

FITT Bluforce RJ introduces an innovative assembly concept for thermoplastic pipes, combining the laying ease of **PVC-A (PVC-HI)*** pipes with socket-based joint and mechanical tightness – a feature found only on other materials up to now.

The Bulldog® system works with a “**double chamber**” structure, as the mechanical and hydraulic seals are supported by two distinct elements. This feature allows for keeping the design allowable operating pressure (PFA) unchanged even though the pipelines have restraint joints: the hydraulic tightness is guaranteed by the EPDM seal while the GJS 450-10 ring housed in the relevant envelope guarantees the mechanical tightness.

Given the “double chamber” structure and the protection ensured by the epoxy coating applied through cataphoresis, the metal parts of the system are entirely preserved from corrosion.

The advantages of using **FITT Bluforce RJ** pipes can be summarised in their easy and quick installation: no special devices are required to insert them nor do costly thrust blocks need to be designed and manufactured. **FITT Bluforce RJ** arrives on-site complete with the Bulldog® system, thus minimising the risk of human error.

Moreover, the pipes can be assembled with extremely limited force, comparable to that required for normal FITT Bluforce pipes.



(*) At a regulatory level, it is defined as a polymeric alloy of Poly Vinyl Chloride with high impact strength PVC-HI (such as PVC-M, PVC-A, PVC-CPE). PVC-HI (PVC-M, PVC-A, PVC-CPE) is a thermoplastic material that contains PVC resin with the addition of an impact modifier (PVC-High Impact). Depending on the type of impact modifier, the acronym HI can be replaced with various designations (PVC-A, Acrylic or PVC-A Alloy (polymer alloy); PVC-CPE, Chlorinated Polyethylene; PVC-M, Modified).

fitt bluforce rj product range pipes and wide radius restraint joint bends



RESTRAINT JOINT PIPE

RESTRAINT JOINT BENDS

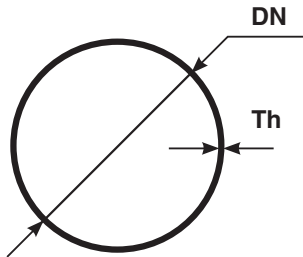
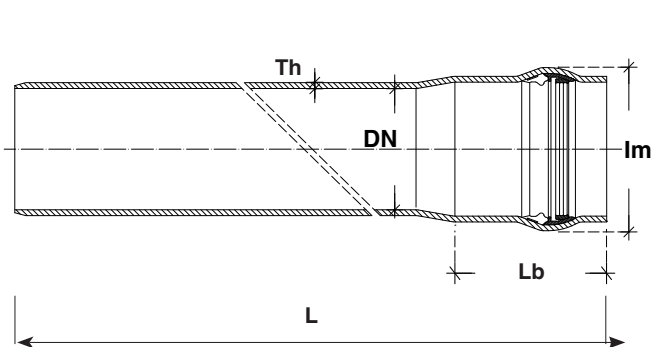

- DN = outside diameter
- L = length of bar
- Ls = length of socket
- Th = thickness
- Im = maximum dimension

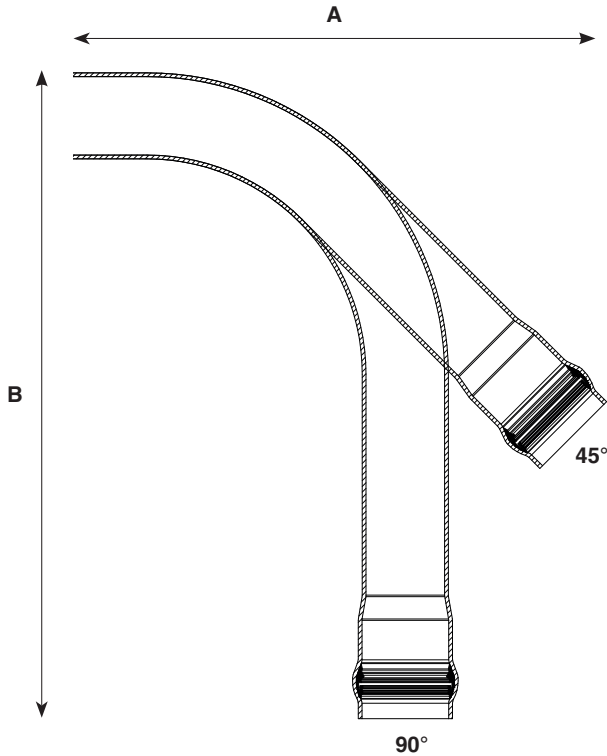

TUBAZIONE ANTIFILAMENTO

Dn [mm]	PN 16			PN 20			Ls [mm]	Im
	Price* [€/m]	Weight [Kg/m]	Th [mm]	Price* [€/m]	Weight [Kg/m]	Th [mm]		
90	27,20	1,70	4,00	32,90	2,02	4,9	165	124
110	33,30	2,53	4,90	40,70	3,02	6,0	170	148
160	62,50	5,20	7,00	85,70	6,33	8,7	200	210
200	97,90	8,15	8,80	133,50	9,88	10,9	230	260
225	124,00	10,38	9,90	168,30	12,55	12,2	245	285
250	152,40	12,74	11,00	205,50	15,45	13,6	260	320
315	243,50	20,10	13,80	327,60	24,45	17,1	300	398
400	414,40	32,34	17,50	515,30	39,28	21,7	330	500

(*) Total length of the bar L = 6m

RESTRAINT JOINT BENDS

PN 16

Dn [mm]	Price* [€/m]	Weight [Kg/m]	Th [mm]	45° [mm]	90° [mm]	Ls [mm]	Im
90	87,38	1,70	4,00	(A) 280 x (B) 900	(A) 380x (B) 900	165	124
110	121,86	2,53	4,90	(A) 350 x (B) 850	(A) 450 x (B) 1.000	170	148
160	188,60	5,20	7,00	(A) 330 x (B) 1.050	(A) 530 x (B) 1.200	200	210
200	314,74	8,15	8,80	(A) 720 x (B) 1.500	(A) 750 x (B) 2.000	230	260
225	419,38	10,38	9,90	**	**	245	285
250	544,29	12,74	11,00	**	**	260	320
315	929,45	20,10	13,80	**	**	300	398
400	-	32,34	17,50	**	**	330	500

(**) Available on request

All the pipes are supplied with protective plugs for the sockets to guarantee the integrity of the seal and facilitate laying operations.
The pipes are available in 6-metre bars.

FITT Bluforce RJ is perfectly compatible with all PVC pipe couplings available on the market (cast iron, steel, PVC-U).

specification item

Supply, transport and laying of **PVC-A (PVC-HI)*** polymer alloy piping conforming to the IIP 1.1/19 technical specification that fully transposes the BS PAS 27/1999 standard, (Italian) Ministerial Decree no. 174/2004 (former circular letter of the Minister of Health no. 102 of 02/12/1978) and the UNI EN 1622 standard – “Water analysis – determination of the threshold odour number (TON) and the threshold flavour number (TFN);” manufactured by ISO 9001-certified companies without any addition of regenerated material and free of leadbased stabilisers.

Socket jointing system with “Bulldog®”- type restraint seal hot-assembled in advance and immovable. The seal consists of an elastomer element conforming to the UNI EN 681-1 standard co-moulded with a GJS 450-10 ductile iron element protected by epoxy resins applied through cataphoresis, which can house a GJS 450-10 mechanical sealing ring protected by epoxy resins applied through cataphoresis.

The jointing system must be capable of withstanding the test conditions required by the standard UNI EN 13844 -13845 -13846.

These performances must be proven by test reports, issued by a certified laboratory. the pipes must be manufactured by companies operating under a Quality Management System conforming to the UNI EN ISO 9001 standard, issued in accordance with the UNI CEI EN 45012 standard by third bodies or companies recognised and accredited by Accredia.

The pipe as described is referenced in UNI 11990-3:2026, the standard for guided drilling systems: Horizontal Directional Drilling (HDD).

The entire supply must be accompanied by a product certification conforming to the IIP 1.1/19 technical specification and according to BS PAS 27/1999 standard issued in accordance with the UNI CEI EN 45011 standard by third bodies or companies recognised and accredited by Accredia. Also it is mandatory to have environmental statement of product in accordance with ISO 14025 Type III, with specific calculation rules for the category of produced according to UNI EN 15804:2012 + A2:2019.

The pipes, supplied in 6-metre elements including the socket and equipped with protective end caps, will be RAL 5010-coloured and must contain the following information printed on one of the crowns: manufacturer’s name or trademark, nominal diameter and thickness, IIP 1.1/19 (alternatively BS PAS 27/1999 and date of issue), date with the production shift, and nominal pressure.



**SCANNEZ le QR Code!
BIM READY**

BIM files of all FITT Bluforce products are available. Scan the QR Code to discover the catalogue of BIM objects!



(*) At a regulatory level, it is defined as a polymeric alloy of Poly Vinyl Chloride with high impact strength PVC-HI (such as PVC-M, PVC-A, PVC-CPE). PVC-HI (PVC-M, PVC-A, PVC-CPE) is a thermoplastic material that contains PVC resin with the addition of an impact modifier (PVC-High Impact). Depending on the type of impact modifier, the acronym HI can be replaced with various designations (PVC-A, Acrylic or PVC-A Alloy (polymer alloy); PVC-CPE, Chlorinated Polyethylene; PVC-M, Modified).

all the advantages of FITT bluforce RJ

RESISTANCE TO IMPACTS



Thanks to its always ductile behaviour, **FITT Bluforce RJ** guarantees high resistance to impacts even at low temperatures, facilitating site operations.

ANTI-CORROSION



FITT Bluforce RJ withstands electrochemical corrosion and is inert to chlorine dioxide used to make the mains water drinkable.

DURABILITY



The polymer alloy (PVC-A) (PVC-HI) technology makes the **FITT Bluforce RJ** pipe for water supply networks and water pipelines highly resistant to crack propagation. This characteristic guarantees a longer service life of the piping and reduced maintenance.

ADVANCED JOINTING SYSTEM



FITT Bluforce RJ adopts the socket-based Power Lock® jointing system with integrated and immovable seal, which ensures rapid assembly of the piping and hydraulic tightness both during the testing phase and over time.

IMPERMEABILITY TO POLLUTANTS



FITT Bluforce RJ is impermeable to the pollutants contained in the soil, protecting the conveyed water against potential contamination.

LOWER MANAGEMENT COSTS FOR THE PRINCIPAL



FITT Bluforce RJ reduces both the time required to build new pipelines and the costs associated with their maintenance.

RESPECTS THE ENVIRONMENT



Thanks to its reduced thickness, **FITT Bluforce RJ** can be manufactured with lower amounts of raw materials and energy required for their transformation. PVC-A (PVC-HI) is 100% recyclable.

EASIER LAYING FOR THE COMPANY



FITT Bluforce RJ guarantees faster, easier and safer pipe laying and drastically reduces potential errors during assembly, guaranteeing positive test results always.

COMPATIBLE SYSTEM



FITT Bluforce RJ can be inserted in new and existing systems thanks to its compatibility with cast iron, steel, PVC-U and HDPE couplings.

insurance certificate



FITT guarantees its products with a specific insurance cover for all damage that may be caused to third parties.

FITT **Bluforce RJ** product is covered by a specific policy with the following conditions:

- **MAXIMUM LIABILITY: EURO 15,000.000**
- **VALIDITY: WORLDWIDE**
- **VALIDITY OF THE COVER FROM THE DATE OF SALE**

The cover for damages also applies the following, insofar as they occur or are presumed to occur: repair, meaning the modification or rectification of the defective product and the installation of the product free of any defects; replacement, i.e. the removal of the defective product and the installation of a corresponding product free of defects.



FITT implements a business management policy aimed at ensuring the highest quality in terms of technology, products and services, in full respect of the environment in which it operates.

The certification of the quality system obtained by the company confirms its compliance with the requirements of the **UNI EN ISO 9001:2015** standard for the following categories:

1) Design, manufacture, storage and distribution of:

- Hoses and systems in plastic material, also suitable for food use, for Garden, Industrial and Building applications, obtained by extrusion and moulding.
- Extruded plastic film.
- Virgin and regenerated PVC granules, obtained through mixing and granulation.

2) Marketing of hoses and systems.

FITT INFRASTRUCTURE SOLUTIONS

This is the business area of the FITT Group that produces and develops complete piping, hose and fitting solutions for the pressure and gravity flow of fluids intended for the integrated water service management utilities, such as drinking water and sewerage networks.

For more information:

FITT S.p.A.

Via Piave, 8
36066 Sandrigo (VI) - Italy
Tel. +39 0444 46 10 00
bluforce@fitt.com
fitt.com

FITT S.p.A. is a Benefit Company according to Italian Law number 208/2015
FITT® is a registered trademark of FITT S.p.A.

