

fitt agix cross 220 recovery unit

RECOVERY UNIT 220 MC/H
E.G. HORIZONTAL INSTALLATION

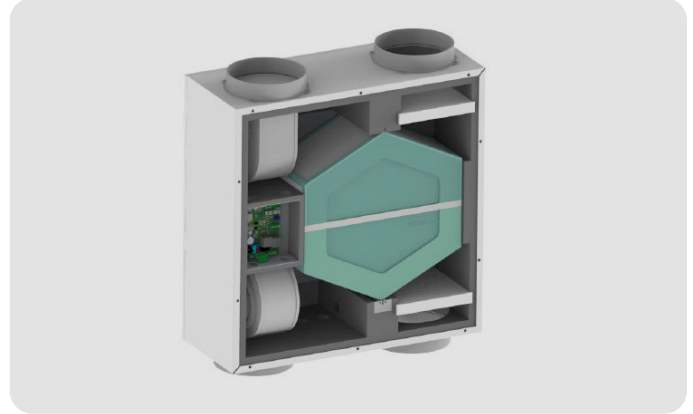

RECOVERY UNIT 220 MC/H
E.G. VERTICAL INSTALLATION



TECHNICAL SPECIFICATIONS

Code	VMAG-220PS	
Fans		
Type of fan	-	centrifugal with forward blades - directly coupled electronic brushless motor
Number of Fans	N.	2
Air flow rate	m ³ /h	200
Useful pressure	Pa	100
Heat exchanger (UNI EN 13141-7, int. temp. 20°C, int. humidity 28%, ext. temp. 7°C, ext. humidity 72%)		
Type of exchanger	-	counter-current plates - polypropylene material
Number of exchangers	N.	1
Recovery efficiency	%	81,1
Filters		
Type of filter	-	flat filters
Filtration class	-	ePM1 80%
Acoustic data (UNI EN 3741 and UNI EN 3744)		
Lw sound power transmitted by the structure	dB(A)	51
Radiated Lw sound power in the channel	dB(A)	56
Average Lp sound pressure at 1m	dB(A)	43,8
Average Lp sound pressure at 3m	dB(A)	36,0
Electrical data		
Supply voltage	V	230 / 1 / 50 Hz
Current consumption	A	1,2
Power consumption	W	130
Protection degree	IP	IPX0

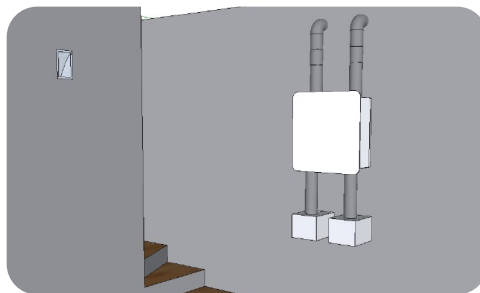
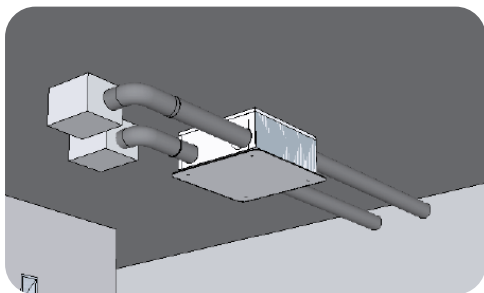

Suitable for both horizontal and vertical installation

HORIZONTAL CEILING INSTALLATION DIMENSIONS

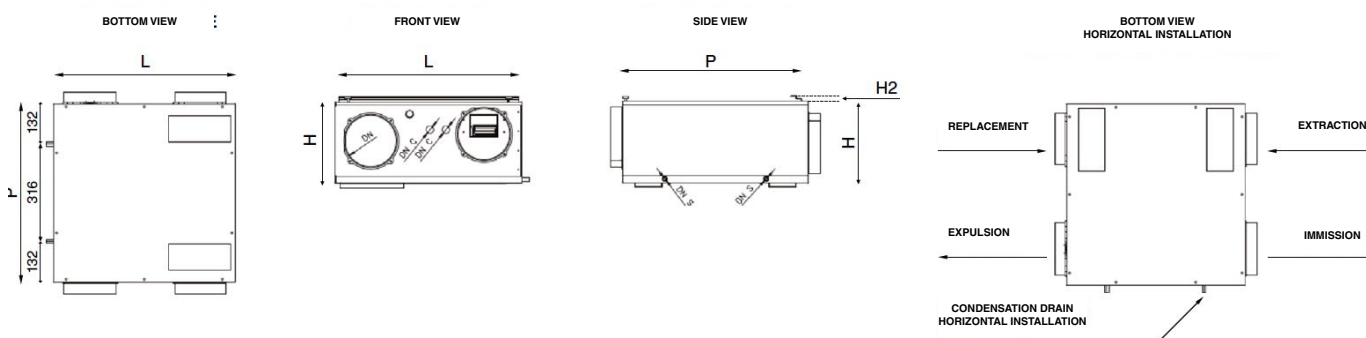

Width L	mm	580
Depth P	mm	580
Height H	mm	255
Bracket height H2	mm	16
Air diameter DN	Ø	160
Condensate drain diameter DN S	mm	12
Cable diameter DN S	mm	16
Weight	Kg	19

HORIZONTAL WALL INSTALLATION DIMENSIONS

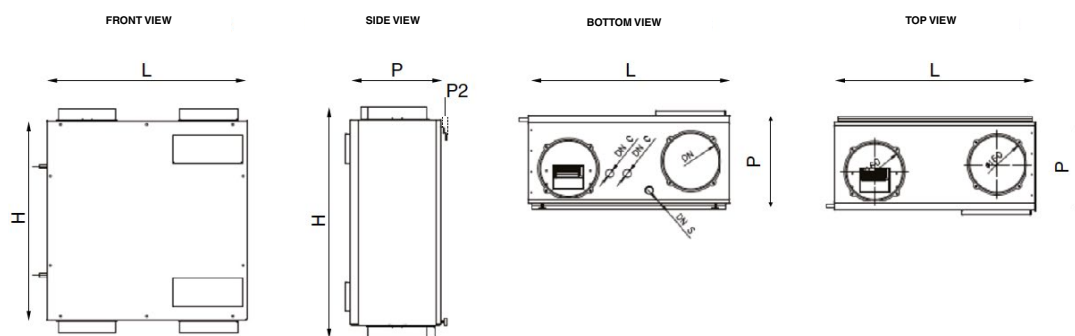

Width L	mm	580
Depth P	mm	255
Height H	mm	580
Bracket height H2	mm	16
Air diameter DN	Ø	160
Condensate drain diameter DN S	mm	20
Cable diameter DN S	mm	16
Weight	Kg	19

CONTROL (INCLUDED)

Removable panel for mounting on 502-503 box or the wall.
Speed, temperature and operating mode control.
Maximum connection length 50m if using a 4-wire twisted shielded cable.
Wi-Fi control for management using a smartphone or tablet and dedicated APP.



AEREAULIC PERFORMANCES

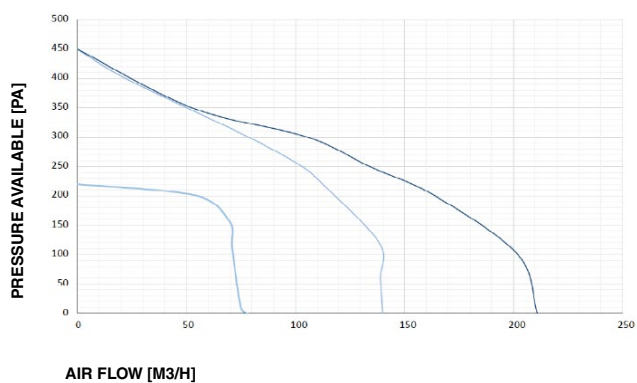

THERMAL EFFICIENCY

